

Mobile Bracket Assembly Instructions

Product Structure

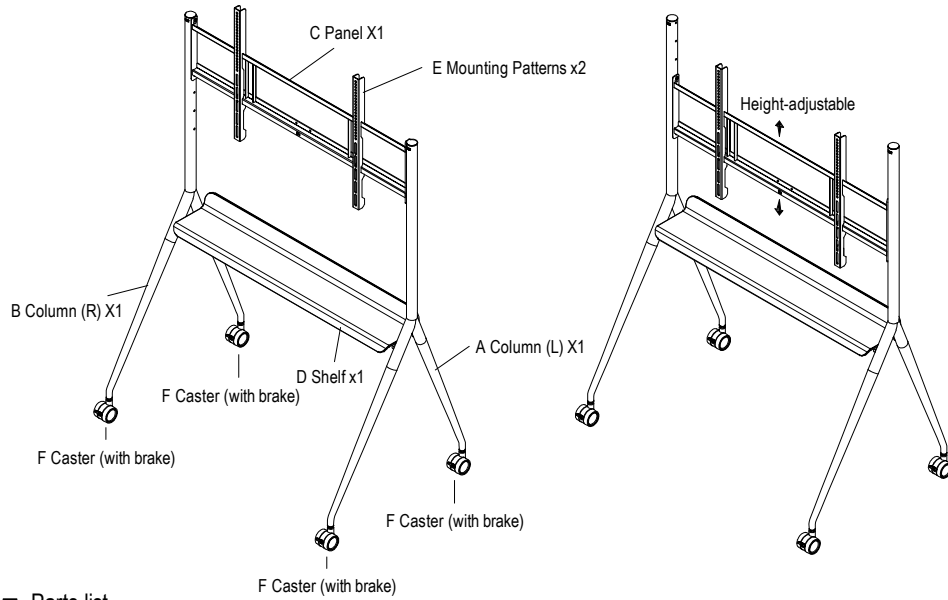

Parts list

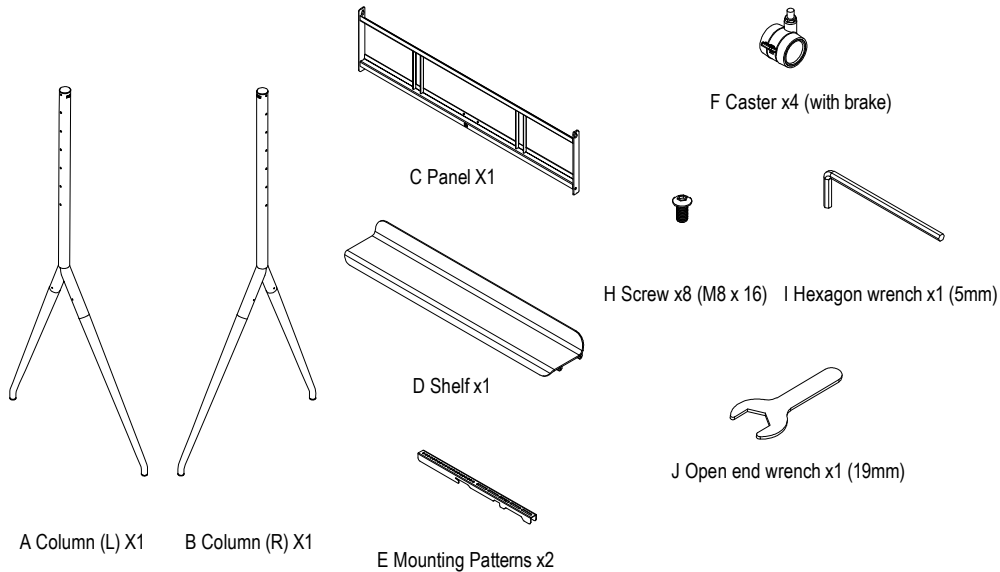

Step-1

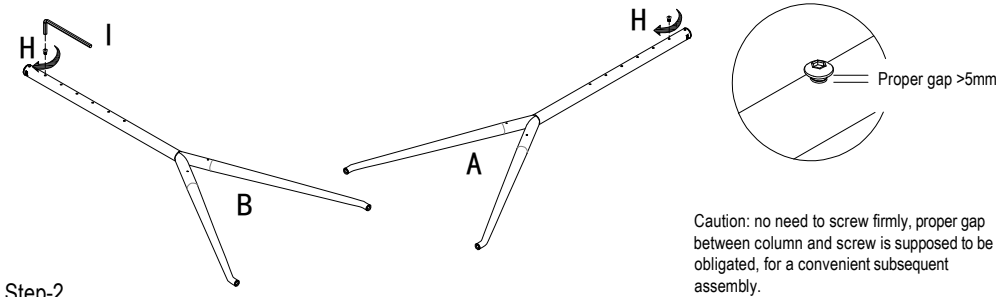

Step-2

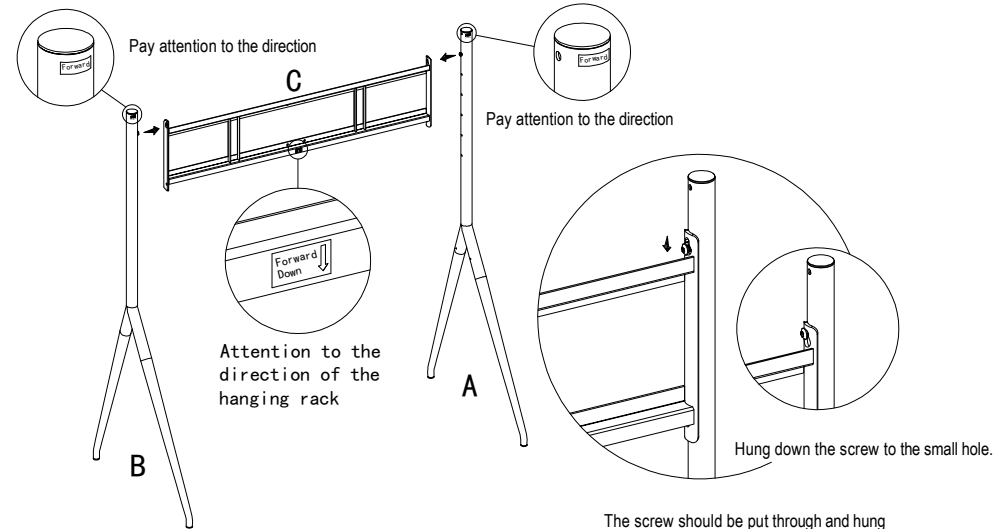

Step-3

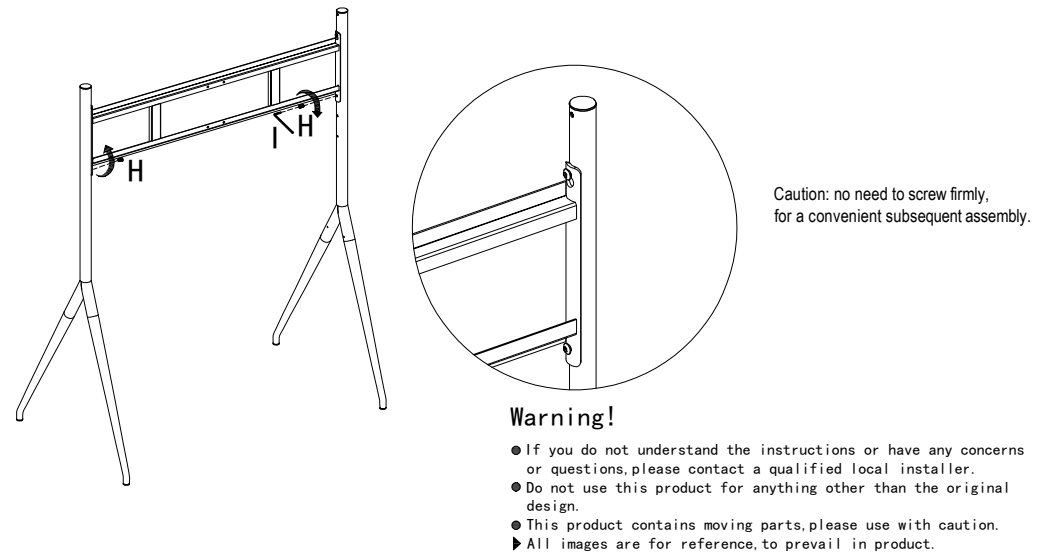

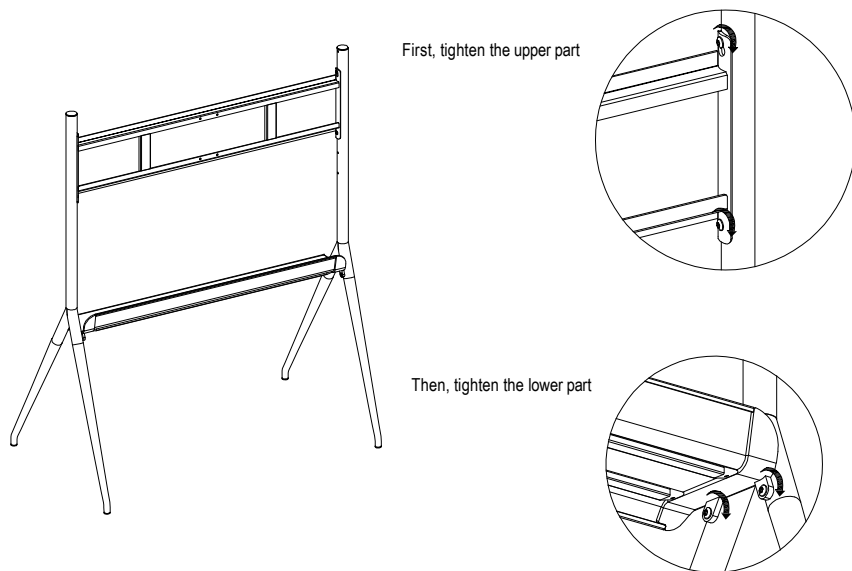
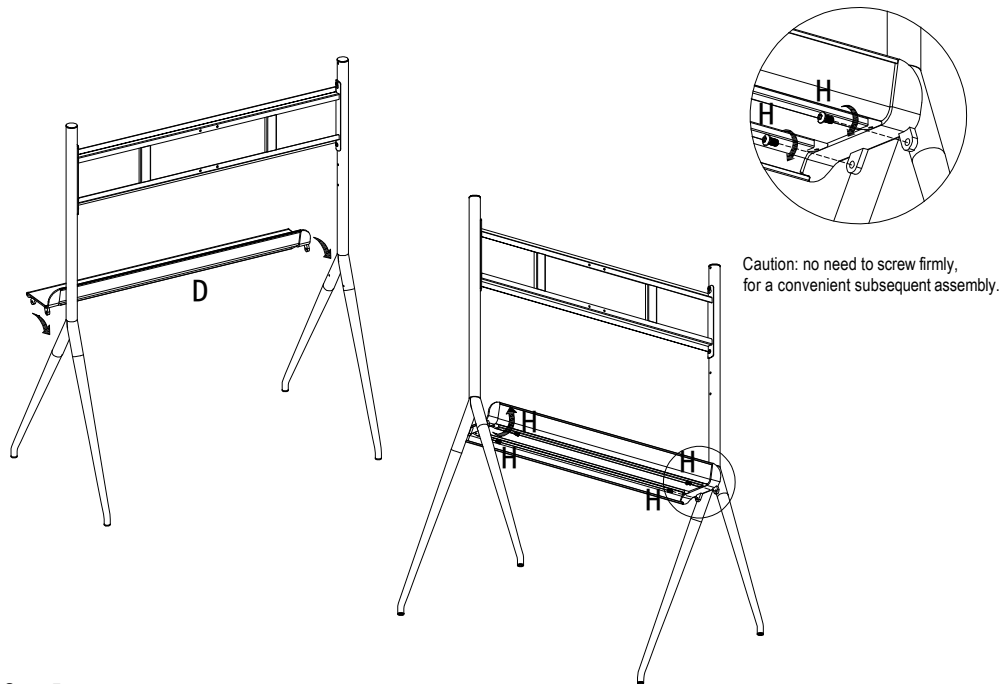

Caution: make sure the cart is put on the level ground, each component is on the right position. Then tighten the screws in sequence.

